

Section A-A

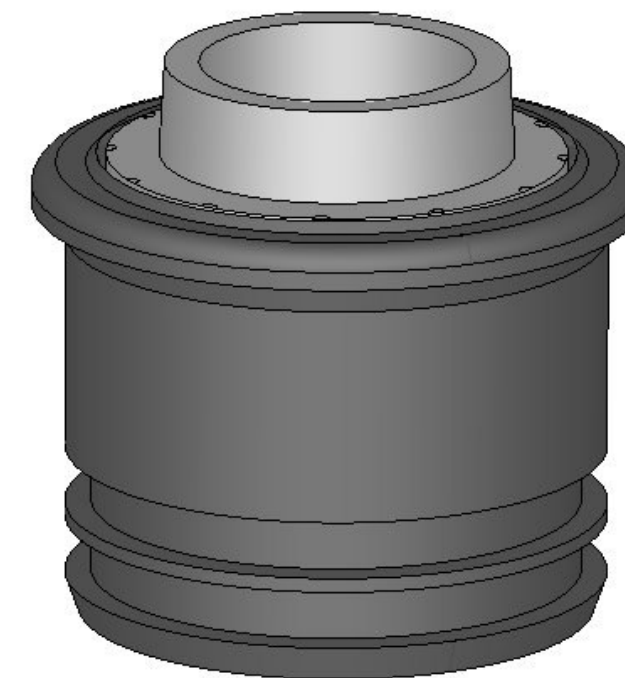

THIS DOCUMENT CONTAINS CONFIDENTIAL AND PROPRIETARY INFORMATION, AND MAY NOT BE USED, COPIED OR DISCLOSED IN WHOLE OR IN PART FOR ANY PURPOSE INCLUDING DESIGN OR MANUFACTURE WITHOUT THE PRIOR WRITTEN CONSENT OF DOYLE MANUFACTURING INC.

REVISION	DESCRIPTION		BY	DATE
DRAWN D. WATERS	DATE	DOYLE MANUFACTURING INC. MAKING PLASTIC MOLDS SINCE 1975. 1440 HOLLOWAY ROAD QUALITY CERTIFIED HOLLAND, OHIO 43528 ISO/TS16949:2002		
TOLERANCE UNLESS SPECIFIED .X = +/- .060 .XXX = +/- .010 .XX = +/- .030 .XXXX = +/- .005				
CUSTOMER SHAMROCK	PART NO. BCFB-R, BCFB-B	PART NAME BATTERY CELL FLOATING BUSHING		
MATERIAL PP W/LEAD INSERT	SHRINKAGE	JOB #	SHT	1
COLOR RED, BLACK	UNITS INCHES		OF	1